



# Premier Lockers

NEW ZEALAND'S LOCKER SPECIALIST



## PREMIER SNUGHOOKS

Premier Snughooks represent the latest and safest hook on the market. Snughooks are smooth-faced, recessed hooks; eliminating the dangers associated with protruding wall hooks. Snughooks are ideal for educational institutes and public areas and can be used to store items such as school bags, minimising potential trip hazards.

### FEATURES

- ▶ The patented and recessed design provides easy use with no protruding hooks, making it one of the safest hook systems available on the market.  
Australian Owned, Designed and Made
- ▶ Designed for Schools - Suitable for all heavy traffic areas that require safe hooks with a high level of wear and tear required.  
UV stabilised allowing for internal or external application
- ▶ Each unit comes with a wall fixing kit and instructions
- ▶ Each unit has been rated to support a combined load of 120kg
- ▶ 10-year product warranty



P: 0800 146 199

[www.premier-lockers.co.nz](http://www.premier-lockers.co.nz)

[sales@premier-lockers.co.nz](mailto:sales@premier-lockers.co.nz)

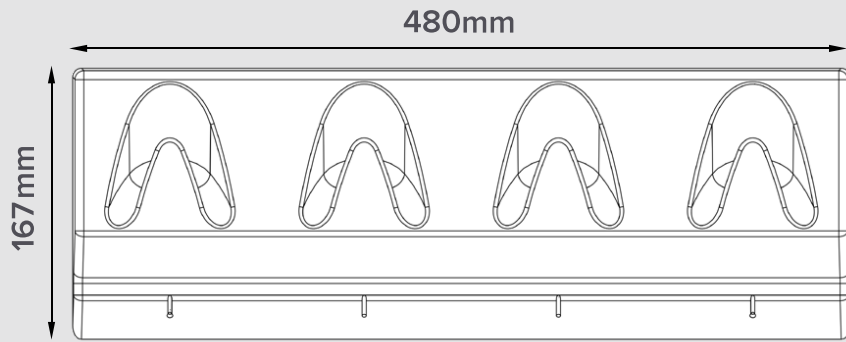

### COLOURS AVAILABLE



### TECHNICAL SPECIFICATIONS

CODE	DESCRIPTION	DIMENSIONS
	Snughooks - 4 Hook System	167H x 480W x 45D

P: 0800 146 199  
[www.premier-lockers.co.nz](http://www.premier-lockers.co.nz)  
[sales@premier-lockers.co.nz](mailto:sales@premier-lockers.co.nz)